

97-Well Rubber Pad



PRODUCT SPECIFICATIONS

Working conditions	Power supply voltage: 220V±10%, 50Hz
Ambient temperature	-10°C-50°C
Relative humidity	20%-90%, no large amount of dust and corrosive gas pollution
Noise	≤50dba
Cover temperature	≤40°C
Preheating time	≤30min
Weight	1kg
Sealing speed	97 holes quantitative detection disk sealing time is less than 15 seconds
Detection range	0-2419MPN/100ml (water sample is not diluted)

METHOD OF USE

1. Open the carton and remove the instrument from the packing box. Leave the packing for future use. First check the appearance and internal damage caused by transportation and other abnormal phenomena. If abnormal discovery is found, please do not sign on the express form. Call 86-029-89011963 quickly to contact with the trading company. 2. Please check accurately

whether the accessories are complete except for the main engine. Other accessory accessories are detailed in six (Accessory accessories).

3. Take out the tray guide slot, Insert the tray guide slot into the hole in front of the sealing machine. Confirm that the tray guide slot is installed in place and ensure that the installation is

firm (Diagram.1, Diagram.2).

4. Confirm that the power switch is closed behind this device. And then take out the power line, Plug the power line into the

instrument 's power jack. Then insert the socket at the other end (Diagram.3, Diagram.4).

5. Turn on the power supply and turn on the power switch (Diagram. 4). Pay attention to checking the radiator fan start work

(Diagram.5). At this point the red indicator lights up. Until the green light is on (Diagram.6), The instrument reaches the working temperature. The preheating is completed.

6. The colitech reagent was added to the quantitative bottle containing 100 ml of water sample (Diagram. 7). Cover the bottle cap, gently shake and mix well. Do not turn over the shock to avoid a lot of bubbles. After fully dissolved, the solution in the quantitative bottle is poured into the quantitative detection plate (Diagram. 8). Tap the lower part of the detection plate to drain bubbles from the detection plate.

7. Take the rubber pad (Diagram.9). The quantitative detection plate containing water samples and colitech reagent is placed in the rubber pad. Notice that each hole of the quantitative plate is aligned to the corresponding hole on the rubber pad. Gently press plate paper surface, so that the quantitative detection plate can be fully adhered with the rubber pad. Note that the opening of the detection plate keeps upwards throughout the operation. Prevent the spilling of the solution during operation (Diagram.10).

8. The quantitative plate and the rubber pad are fixed, and the opening of the quantitative plate is upward. Tilt the rubber pad into the guide slot and gently push it into the sealing machine inlet (Diagram.11). The instrument can automatically drive the rubber pad into the instrument until the instrument grabs the rubber pad then loosens the hand. (Diagram.12)

9. About 15 seconds, after the seal is finished, The quantitative plate and the quantitative rubber pad are simultaneously released from the instrument (Diagram.13). Take of the seal 's quantitative plate (Diagram.14). The back of the quantitative plate (paper surface) can mark the relevant information of the water sample. For example, water samples are like drinking water, surface water, underground water and so on. Sample number, sampling time, sampling point, sample dilution times, culture start time, etc.

10. In the incubator, if the coliform and Escherichia coli were detected, The temperature of the incubator is set to $36\pm 1^{\circ}\text{C}$. For determination of fecal coliform (thermotolerant coliform) The incubator was set at $44.5\pm 0.2^{\circ}\text{C}$ and incubate $24\text{h}\pm 2\text{h}$.

11. According to the positive results (yellow was positive for total and fecal coliform). The positive of Escherichia coli was fluorescence (Diagram.15), No color change was negative for total, fecal coliform, and no fluorescence for Escherichia coli negative. Count the number of yellow or fluorescent positive holes, check 51 or 97 hole MPN table (Diagram.16). The results showed that the number of coliform bacteria in 100 ml water sample was the same. According to the dilution multiple, the results are calculated according to the following formula: Coliform (MPN/L) = MPN value x dilution multiple x 1000mL/100mL

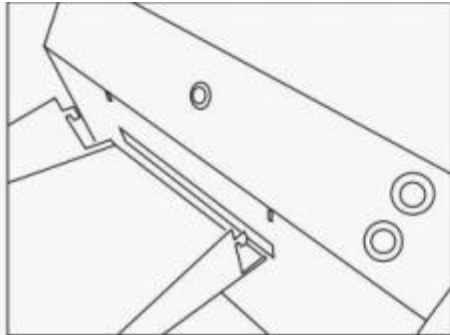

Tray guide slot installation diagram 1

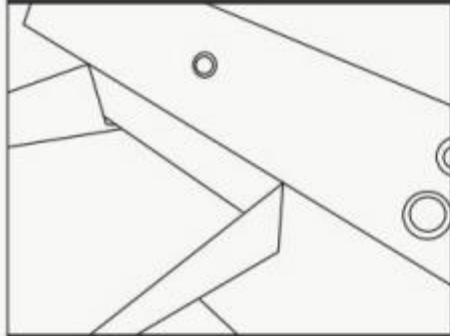

Tray guide slot installation diagram 2

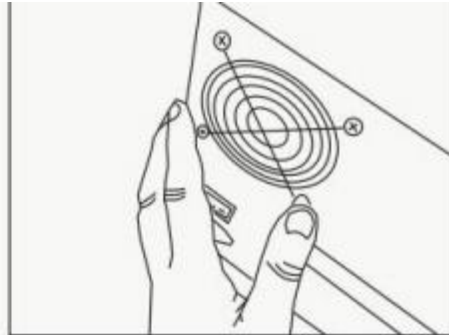

Instrument opening check diagram 5

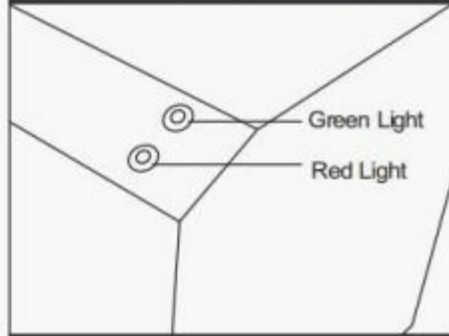

Instrument opening check diagram 6

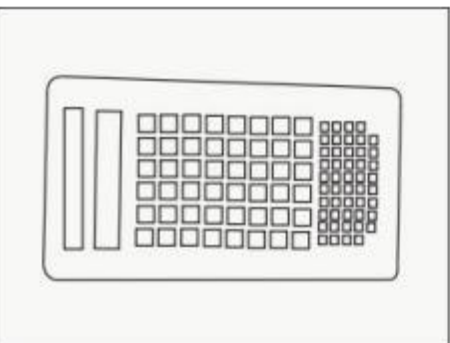

Inspection operation diagram 9

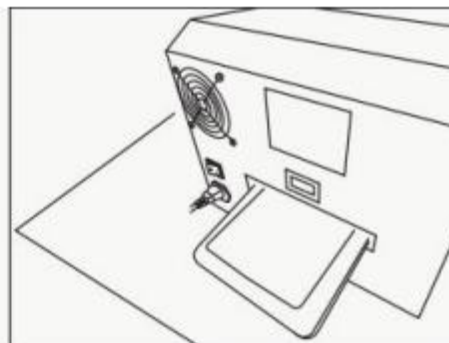

Inspection operation diagram 13

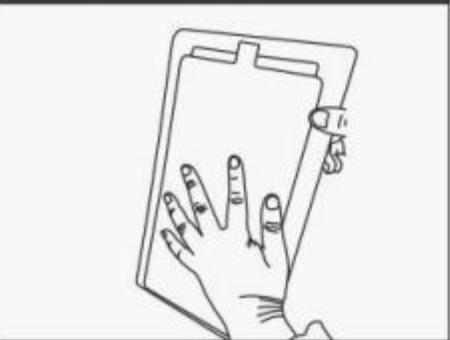

Inspection operation diagram 10



Inspection operation diagram 14

POINTS TO NOTE

1. Please operate the machine strictly according to the instruction manual. Otherwise, it may cause injury, damage to machine, property loss and inaccuracy of test results.
2. do not place beaker, measuring cylinder and other glassware on the sealing machine, so as not to break the water into the sealing machine. .
3. Do not push the articles of non 51 or 97 hole plate and rubber pad into the sealing machine, otherwise the instrument will be damaged..
4. The operator, once the hand, hair, sleeves, etc. are inserted into the sealing machine, press the reverse button at the front entrance of the sealing machine to avoid danger.
5. At any time, if it is necessary to reverse the instrument, exit the rubber pad and the quantitative plate from the direction of the import (for example, when the tray guide slot is not leveled and put the rubber pad into the machine), please press the reverse button on the sealing machine. However, when the rubber pad has completely entered the machine, please do not press the reverse button.
6. If there are more than one rubber pad, it can be continuously placed into the machine for sealing.
7. After the experiment, please turn of the power switchfirst, then unplug the power supply.
8. There is a high voltage power supply inside the machine.